



Electrical & Automation



EXPERIENCE **PEACE OF MIND**
Final Distribution Products - Tripper



ABOUT US

Lauritz Knudsen Electrical & Automation, formerly known as L&T Switchgear, is a leading player in the electrical industry owing to its 70+ years of strong legacy and commitment to the nation's growth. The brand is dedicated to providing a wide range of electrical and automation products and solutions to vital sectors of the economy, including industries, utilities, infrastructure, buildings, and agriculture. Our extensive portfolio includes low-voltage and medium-voltage switchgear, automation solutions, tailored software, and services.

With manufacturing operations in Ahmednagar, Vadodara, and Coimbatore, we adhere to global standards of excellence. Our operations are supported by well-equipped, in-house design and development centers, as well as tooling facilities, ensuring precision in manufacturing.

We proudly operate six Switchgear Training Centers (STCs) across Pune, Lucknow, Coonoor, Vadodara, Delhi, and Kolkata. These centers offer tailor-made classroom courses and lab learning experiences for technicians, customers, engineers, professionals, and students.

With a deep national presence and one of the largest electrical distribution networks, comprising over 1500 partners across the country, we are committed to driving excellence and delivering superior products and solutions that power India's growth journey.

Contents

| | |
|---|-----------|
| TRIPPER MODULAR DEVICES | 1 |
| MCBs (Miniature Circuit Breakers) | 3 |
| Isolators | 5 |
| RCCBs / ELCBs (Residual Current / Earth Leakage Circuit Breakers) | 6 |
| EL+MCBs/ RCBOs (Residual Current Circuit Breakers with Overcurrent protection) | 7 |
| ACCL (Automatic Changeover Current Limiter) | 9 |
| TRIPBOX PLUS | 11 |
| SPN DBs | 13 |
| TPN DBs | 14 |
| Horizontal PPI DBs | 15 |
| Phase Segregated DBs | 16 |
| Phase Selector DBs | 17 |
| VTPN DBs with Modular Incomer | 18 |
| VTPN DBs with MCCB Incomer | 19 |
| Enclosures | 20 |
| Plug & Socket DBs | 21 |
| TRIPBOX | 22 |

Tripper[®]
Modular Devices



The Range that Spells Value



Safety you can trust



True Contact Indication

The Tripper range enhances safety through true contact indication even from a distance, regardless of its knob position. Red and Green indication flag provided below the knob positively identify the electrical ON/OFF status.



World-class Safety Standards

Tripper products conform to relevant global standards, viz., IEC, EN and ISI. They also have CE / ISI marking and KEMA certification.



Safety Redefined

Finger-proof terminals eliminate the chances of accidental contact with live parts. You can install, operate and maintain Tripper with total confidence.



Non-welding Contacts

Silver graphite contact tips ensure longer life and maximum safety against contact welding due to their superior anti-welding properties.



Easier installation, longer-lasting



Large Terminal Size and Dual Termination

Tripper can easily accommodate cables of up to 35 sq. mm. The terminals are designed to facilitate termination of cable or busbar or both at incomer side. Tripper terminals offer simple termination flexibly.



Two-position DIN rail clip

Installation on a DIN rail is further simplified with a two-position DIN rail clip as a standard feature. The Tripper range makes mounting on a standard DIN rail more convenient than others.

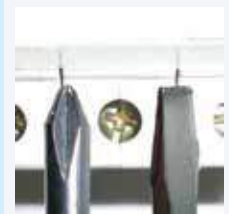

Combihead Screw

The Tripper range of products, provided with combihead screws, allows you to use standard as well as Philips screw drivers. The Tripper range addresses all your unidentified needs.

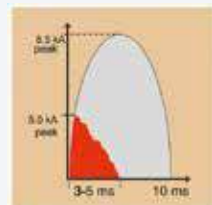

Energy-limiting Class - 3

If a fault occurs, the Rapid Arc Quenching mechanism in Tripper extinguishes the arc quickly (within 3-5 msec), ensuring the lowest possible energy flow through the circuit. This minimises the risk of fire and maximises the life of your equipment.



Safety meets Superior Aesthetics

Ergonomically designed, profiled for superior cooling, and manufactured with fire-retardant material, Tripper offers you safety combined with elegance.



Innovatively profiled Breathing Channels

The Tripper range of products, provided with combihead screws, allows you to use standard as well as Philips screw drivers. The Tripper range addresses all your unidentified needs.



MCBs (Miniature Circuit Breakers)



Highlights

- › - marked, CE - marked
- › Conforms to IS / IEC 60898
- › Longer life because of heavy-duty contacts
- › Cooling operation due to breathing space between two poles
- › Energy saving, i.e. low watt loss (50%) as compared to standards
- › Manufactured using high-quality fire-retardant material
- › True contact indication for enhanced safety
- › No line-load bias

Technical Specifications

| | |
|------------------------------------|---|
| Tripping Characteristics | B & C curve |
| Rated Operational Voltage | 240/415 V AC |
| Rated Breaking Capacity | 6 kA as per EN/IEC 60898-1 |
| Rated Frequency | 50/60 Hz |
| Electrical Life (Operating Cycles) | 10,000 cycles |
| Mechanical Life (Operating Cycles) | 1,00,000 cycles |
| Rated Insulation Voltage | 500 V AC |
| Terminal Capacity | 35 sq. mm (rigid) 25 sq. mm (flexible) |

Miniature Circuit Breakers (MCBs) - B Curve



| Rating | Single-Pole Cat. Nos. |
|--------|-----------------------|
| 6A | BA10060B |
| 10A | BA10100B |
| 16A | BA10160B |
| 20A | BA10200B |
| 25A | BA10250B |
| 32A | BA10320B |
| 40A | BA10400B |

Miniature Circuit Breakers (MCBs) - C Curve



| Rating | Single-Pole Cat. Nos. | Double-Pole Cat. Nos. | Three-Pole Cat. Nos. | Four-Pole Cat. Nos. |
|--------|-----------------------|-----------------------|----------------------|---------------------|
| 6A | BA10060C | BA20060C | BA30060C | BA40060C |
| 10A | BA10100C | BA20100C | BA30100C | BA40100C |
| 16A | BA10160C | BA20160C | BA30160C | BA40160C |
| 20A | BA10200C | BA20200C | BA30200C | BA40200C |
| 25A | BA10250C | BA20250C | BA30250C | BA40250C |
| 32A | BA10320C | BA20320C | BA30320C | BA40320C |
| 40A | BA10400C | BA20400C | BA30400C | BA40400C |
| 63A | BA10630C | BA20630C | BA30630C | BA40630C |

Dimensions

All dimensions are in mm

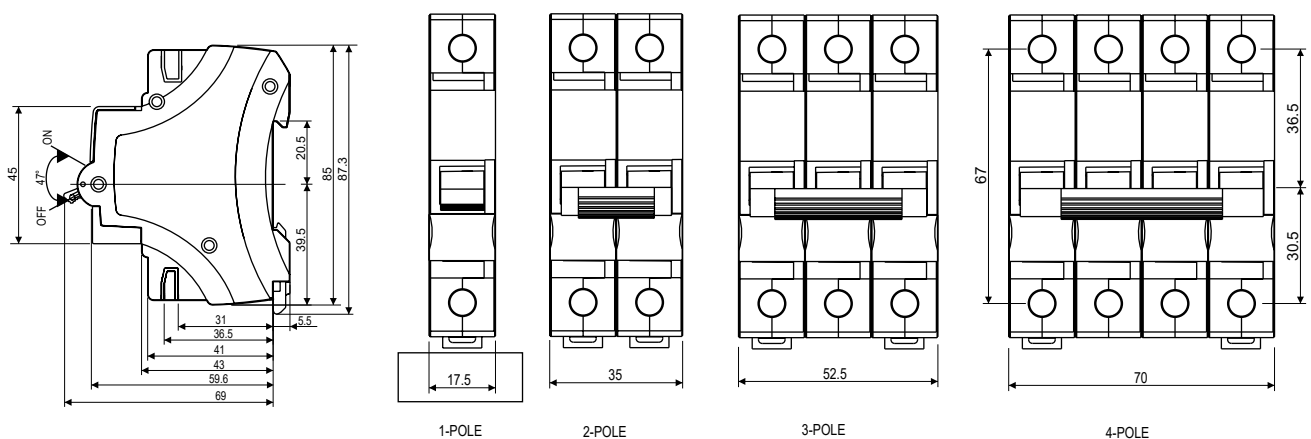

Isolators



Highlights

- › CE - marked
- › Conforms to IEC 60947-3
- › Longer life because of heavy-duty contacts
- › Cooler operation due to breathing space between two poles
- › Energy saving, i.e. low watt loss (50%) as compared to standards
- › Manufactured by using high-quality fire-retardant material
- › True contact indication for enhanced safety

Technical Specifications

| | |
|------------------------------------|--|
| Rated Operational Voltage | 240/415 V AC |
| Rated Insulated Voltage | 500 V AC |
| Rated Impulse Withstand Voltage | 4 kV |
| Short Time Withstand, Icw | 12In, 1 sec |
| Short Circuit Making Capacity, Icm | 3 kA |
| Rated Frequency | 50/60 Hz |
| Electrical Life (Operating Cycles) | 10,000 cycles |
| Mechanical Life (Operating Cycles) | 1,00,000 cycles |
| Utilization Category | AC-22A |
| Terminal Capacity | 35 sq. mm (rigid) / 25 sq. mm (flexible) |



| Rating | Double-Pole Cat. Nos. | Three-Pole Cat. Nos. | Four-Pole Cat. Nos. |
|--------|-----------------------|----------------------|---------------------|
| 40A | BE204000 | BE304000 | BE404000 |
| 63A | BE206300 | BE306300 | BE406300 |
| 100A | BE210000 | BE310000 | BE410000 |

Dimensions

All dimensions are in mm

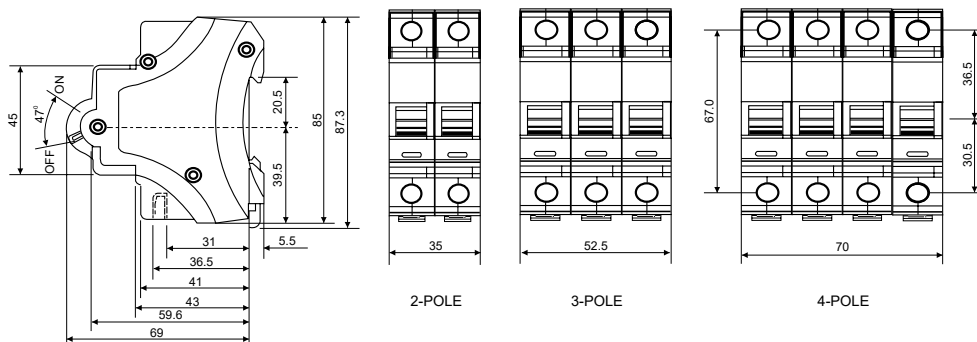

RCCBs / ELCBs (Residual Current / Earth Leakage Circuit Breakers)



Highlights

- › Conforms to IS 12640-1, IEC 61008-1
- › Dual Termination
- › Available in SPN & TPN with 30mA, 100mA and 300mA sensitivity
- › Operates on Core Balance Current Transformer
- › Finger-proof terminal

Technical Specifications

| | |
|------------------------------------|--|
| Rated Operational Voltage | 240/415 V AC |
| Rated Conditional SC current | 6 kA |
| Rated Impulse withstand Voltage | 4 kV |
| Rated Insulation Voltage | 500 V AC |
| Rated Frequency | 50/60 Hz |
| Electrical Life (Operating Cycles) | 10,000 cycles |
| Mechanical Life (Operating Cycles) | 20,000 cycles |
| Terminal Capacity | 50 sq. mm (rigid) / 35 sq. mm (flexible) |



Double-Pole

Four-Pole

| Double-Pole | |
|------------------|-----------|
| Description | Cat. Nos. |
| 2-Pole 25A 30mA | BC202503 |
| 2-Pole 25A 100mA | BC202510 |
| 2-Pole 25A 300mA | BC202530 |
| 2-Pole 40A 30mA | BC204003 |
| 2-Pole 40A 100mA | BC204010 |
| 2-Pole 40A 300mA | BC204030 |
| 2-Pole 63A 30mA | BC206303 |
| 2-Pole 63A 100mA | BC206310 |
| 2-Pole 63A 300mA | BC206330 |

| Four-Pole | |
|------------------|-----------|
| Description | Cat. Nos. |
| 4-Pole 25A 30mA | BC402503 |
| 4-Pole 25A 100mA | BC402510 |
| 4-Pole 25A 300mA | BC402530 |
| 4-Pole 40A 30mA | BC404003 |
| 4-Pole 40A 100mA | BC404010 |
| 4-Pole 40A 300mA | BC404030 |
| 4-Pole 63A 30mA | BC406303 |
| 4-Pole 63A 100mA | BC406310 |
| 4-Pole 63A 300mA | BC406330 |

Dimensions

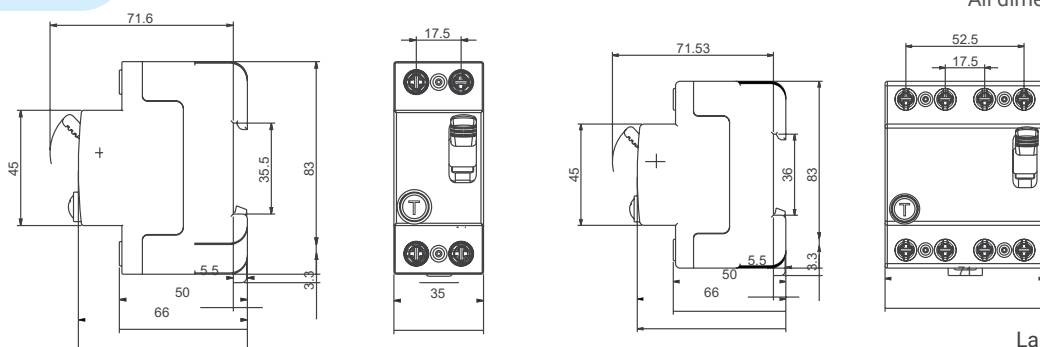

All dimensions are in mm

EL+MCBs/ RCBOs (Residual Current Circuit Breakers with Overcurrent Protection)



Highlights

- › Combination of RCCB/ELCB & MCB (RCBO/EL+MCB) offers 3-in-1 protection against overload, short circuit and earth leakage
- › Saves human life from electric shock and protects buildings from fire
- › Quality assured by a test certificate provided with each EL+MCB
- › Easy fault identification – both knobs come down for earth leakage tripping and only MCB knob comes down for overload tripping

EL+MCBs (RCBO) - 2-Pole



Double-Pole

| Description | Cat. Nos. (30mA) | Cat. Nos. (100mA) | Cat. Nos. (300mA) |
|-----------------|------------------|-------------------|-------------------|
| 6A 2P ELCB+MCB | CB9000100TO | CB9000300TO | CB9000500TO |
| 10A 2P ELCB+MCB | CB9000100VO | CB9000300VO | CB9000500VO |
| 16A 2P ELCB+MCB | CB9000100BO | CB9000300BO | CB9000500BO |
| 20A 2P ELCB+MCB | CB9000100CO | CB9000300CO | CB9000500CO |
| 25A 2P ELCB+MCB | CB9000100DO | CB9000300DO | CB9000500DO |
| 32A 2P ELCB+MCB | CB9000100EO | CB9000300EO | CB9000500EO |
| 40A 2P ELCB+MCB | CB9000100FO | CB9000300FO | CB9000500FO |
| 63A 2P ELCB+MCB | CB9000100HO | CB9000300HO | CB9000500HO |

EL+MCBs (RCBO) - 4-Pole



Four-Pole

| Description | Cat. Nos. (30mA) | Cat. Nos. (100mA) | Cat. Nos. (300mA) |
|-----------------|------------------|-------------------|-------------------|
| 6A 4P ELCB+MCB | CB9000200TO | CB9000400TO | CB9000600TO |
| 10A 4P ELCB+MCB | CB9000200VO | CB9000400VO | CB9000600VO |
| 16A 4P ELCB+MCB | CB9000200BO | CB9000400BO | CB9000600BO |
| 20A 4P ELCB+MCB | CB9000200CO | CB9000400CO | CB9000600CO |
| 25A 4P ELCB+MCB | CB9000200DO | CB9000400DO | CB9000600DO |
| 32A 4P ELCB+MCB | CB9000200EO | CB9000400EO | CB9000600EO |
| 40A 4P ELCB+MCB | CB9000200FO | CB9000400FO | CB9000600FO |
| 63A 4P ELCB+MCB | CB9000200HO | CB9000400HO | CB9000600HO |

Technical Specifications

| | |
|------------------------------------|-------------------------|
| Tripping Characteristics | C curve : 6 A to 63 A |
| Rated Operational Voltage | 240/415 V AC |
| Rated Breaking Capacity | 6 kA as per IEC 61009-1 |
| Rated Impulse withstand Voltage | 4 kV |
| Rated Insulation Voltage | 500 V AC |
| Rated Frequency | 50/60 Hz |
| Electrical Life (Operating Cycles) | 10,000 cycles |
| Mechanical Life (Operating Cycles) | 20,000 cycles |
| Terminal Capacity | 25 sq. mm |

Dimensions

All dimensions are in mm

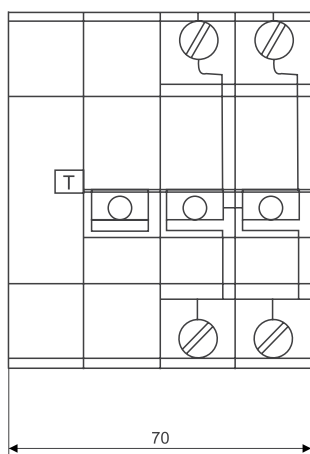
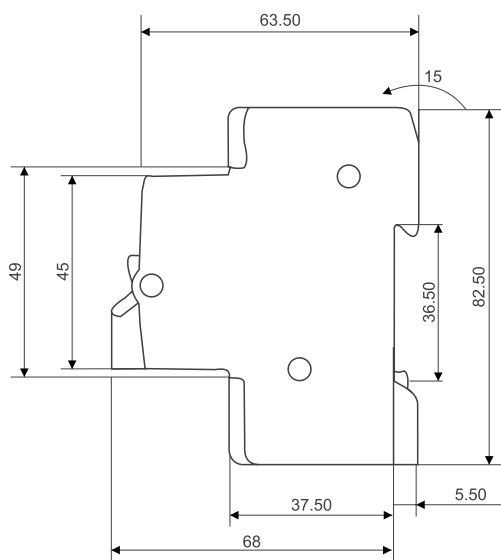

2-POLE

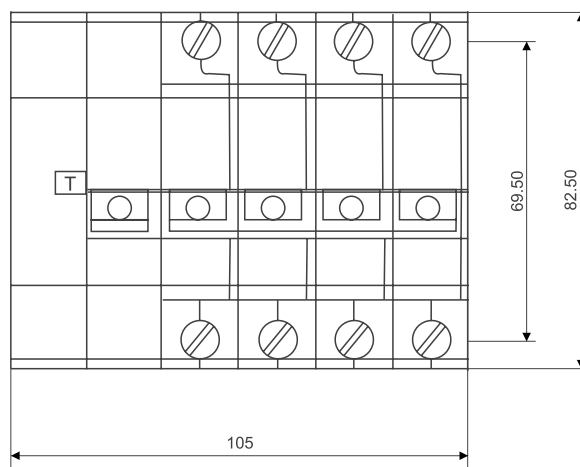

4-POLE

ACCL (Automatic changeover with current limiter)



Highlights

- › Conforms to IEC 60947-6, IEC 60947-3
- › Wide Range of Current Ratings: (Generator side) – 1.5A to 30A, (Electricity Boards side) – 30A
- › No. of Poles 1P+N
- › Protection Degree - IP20
- › Reliable microcontroller based design for sensing & control
- › Lower power consumption
- › RoHS compliant



Technical Specifications

| | |
|------------------------------------|----------------------------|
| Rated Operational Voltage | 230V |
| Rated Insulation Voltage | 500 V |
| Rated Impulse Voltage | 2.5kV |
| Rated Frequency | 50Hz |
| Electrical Life (Operating Cycles) | 6000 |
| Utilization Category | AC 31B (IEC 60947-6) |
| | AC 21A (IEC 60947-3) |
| Conditional short-circuit current | 3kA |
| Dielectric strength | 2kV |
| Changeover time (Mains to DG) | ~ 11 sec. |
| Terminal Capacity | AC-22A |
| | 10 mm ² (rigid) |
| Operating Temperature | -5°C to 50°C |



| Single Phase ACCL | Modules | Cat. Nos. |
|-------------------|---------|-------------|
| 30A/1.5A | 4 | BCL010301E5 |
| 30A/2.5A | 4 | BCL010302E5 |
| 30A/3A | 4 | BCL01030003 |
| 30A/4A | 4 | BCL01030004 |
| 30A/5A | 4 | BCL01030005 |
| 30A/6A | 4 | BCL01030006 |
| 30A/8A | 4 | BCL01030008 |
| 30A/10A | 4 | BCL01030010 |
| 30A/12A | 4 | BCL01030012 |
| 30A/15A | 4 | BCL01030015 |
| 30A/20A | 4 | BCL01030020 |
| 30A/30A | 4 | BCL01030030 |

Dimensions

All dimensions are in mm

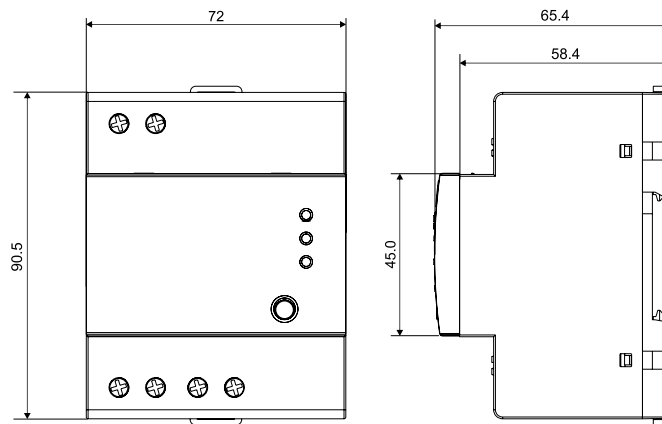

Connection Diagram

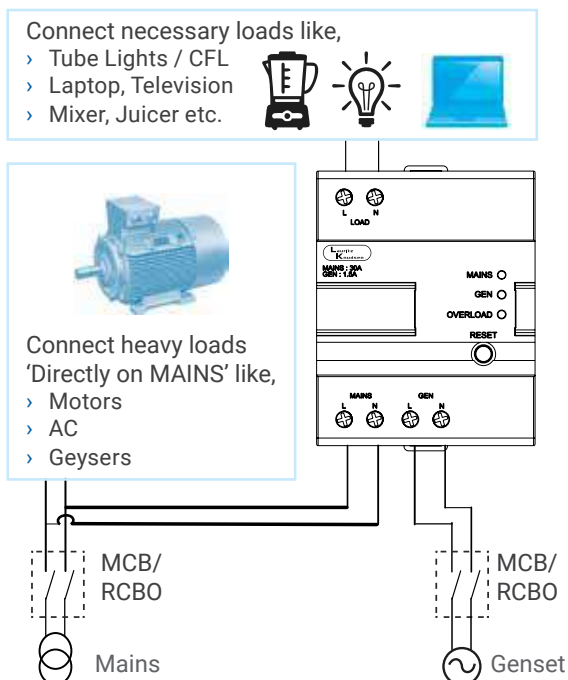

Recommended Backup MCB Ratings

| ACCL Ratings | | MCB Ratings | | ACCL Cat. Nos. |
|--------------|--------|---------------|----------------|----------------|
| Mains | Genset | On Mains Side | On Genset Side | |
| 30A | 1.5A | 32A | 2A | BCL010301E5 |
| | 2.5A | | 3A | BCL010302E5 |
| | 3A | | 3A | BCL01030003 |
| | 4A | | 4A | BCL01030004 |
| | 5A | | 5A | BCL01030005 |
| | 6A | | 6A | BCL01030006 |
| | 8A | | 10A | BCL01030008 |
| | 10A | | 10A | BCL01030010 |
| | 12A | | 16A | BCL01030012 |
| | 15A | | 16A | BCL01030015 |
| | 20A | | 20A | BCL01030020 |
| 30A | 32A | BCL01030030 | | |

Timing Diagram

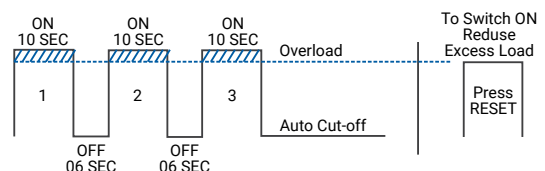

Tripbox PLUS



Tripbox PLUS

Value + Style

- › The TripBox PLUS range of Distribution Boards (DBs) offers the perfect blend of aesthetics and value.
- › Crafted for modern homes, its features ensure ease of installation, enhanced safety, and protection from accidental damage – with a dash of style.



Safety + Style

Options for flush and surface mounting

Pleasing powder-coated, matte finish RAL9003

Insulated Busbar



As per IS 8623 Standards

Shrouded neutral bars to avoid accidental contact with live parts



Ease of Installation

Reversible door for double-door Distribution Boards to adapt to site conditions



More space for ease of wiring



Protection from Damage

CRCA sheet steel for extra durability

Plastic corners for corner protection



Cement Spill Protector – to protect DB interior from cement splashes during civil work



SPN DBs

Metal DBs for Single Phase and Neutral (SPN) supply distribution

- › As per IS 8623
- › Available in 4, 6, 8,12 & 16-way
- › Choice of metal or glazed door
- › Provision for DP MCB / Isolator / RCCB / RCBO as incomer and SP MCBs as outgoing
- › Ready-to-use DB complete with colour-coded wire set, 100A insulated bus bar, neutral bar/s with shroud/s, earth bar/s, cement-spill protector, cable ties, blanking plates and circuit identification label



Ordering Info.

| Description | Modules | | IP43 Double Door | IP43 Glazed Door |
|---------------|---------|----------|------------------|------------------|
| | Incomer | Outgoing | | |
| 4-way (2+2) | 2 | 2 | PH104DDB | PH104DDG |
| 6-way (2+4) | 2 | 4 | PH106DDB | PH106DDG |
| 8-way (2+6) | 2 | 6 | PH108DDB | PH108DDG |
| 12-way (2+10) | 2 | 10 | PH112DDB | PH112DDG |
| 16-way (2+14) | 2 | 14 | PH116DDB | PH116DDG |

Dimensions

IP43 Double Door – Metal Door

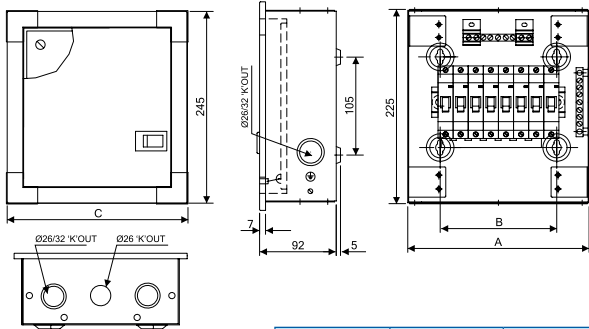

| Way | A | B | C | Top/Bottom Ø26 | Top/Bottom Ø26/32 | Side 'K'OUT Ø26/32 |
|-----|-----|-----|-----|-------------------|----------------------|--------------------------|
| 4 | 140 | 65 | 160 | — | 4 Nos. | 2 Nos. |
| 6 | 175 | 100 | 195 | — | 4 Nos. | 2 Nos. |
| 8 | 210 | 135 | 230 | 2 Nos. | 4 Nos. | 2 Nos. |
| 12 | 285 | 210 | 305 | 4 Nos. | 4 Nos. | 2 Nos. |
| 16 | 365 | 290 | 385 | 6 Nos. | 4 Nos. | 2 Nos. |

IP43 Double Door – Glazed Door

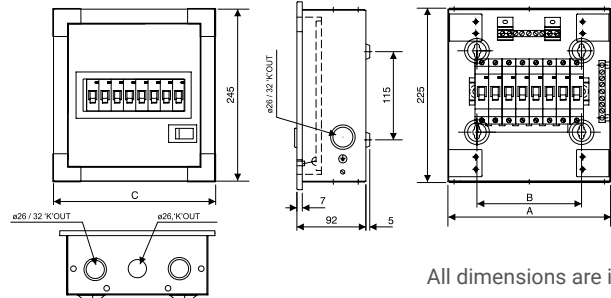

All dimensions are in mm

| Way | A | B | C | Top/Bottom Ø26, 'K'OUT | Top/Bottom Ø26/32 'K'OUT | Side 'K'OUT Ø26/32 'K'OUT |
|-----|-----|-----|-----|------------------------------|--------------------------------|------------------------------------|
| 4 | 140 | 65 | 160 | — | 4 Nos. | 2 Nos. |
| 6 | 175 | 100 | 195 | — | 4 Nos. | 2 Nos. |
| 8 | 210 | 135 | 230 | 2 Nos. | 4 Nos. | 2 Nos. |
| 12 | 285 | 210 | 305 | 4 Nos. | 4 Nos. | 2 Nos. |
| 16 | 365 | 290 | 385 | 6 Nos. | 4 Nos. | 2 Nos. |

TPN DBs

Metal DBs for Three-Phase and Neutral (TPN) supply distribution

- › As per IS 8623
- › Available in 4, 6, 8 & 12-way
- › Choice of metal or glazed door
- › Provision for FP MCB / Isolator / RCCB / RCBO as incomer and SP MCBs as outgoing
- › Ready-to-use DB complete with colour-coded wire set, 100A insulated busbar, neutral bar/s with shroud/s, earth bar/s, cement-spill protector, cable ties, blanking plates and circuit identification label



Ordering Info.

| Description | Modules | | IP43 Double Door | IP43 Glazed Door |
|-------------|---------|----------|------------------|------------------|
| | Incomer | Outgoing | | |
| 4-way | 8 | 4+4+4 | PH304DDB | PH304DDG |
| 6-way | 8 | 6+6+6 | PH306DDB | PH306DDG |
| 8-way | 8 | 8+8+8 | PH308DDB | PH308DDG |
| 12-way | 8 | 12+12+12 | PH312DDB | PH312DDG |

Dimensions

IP43 Double Door – Metal Door

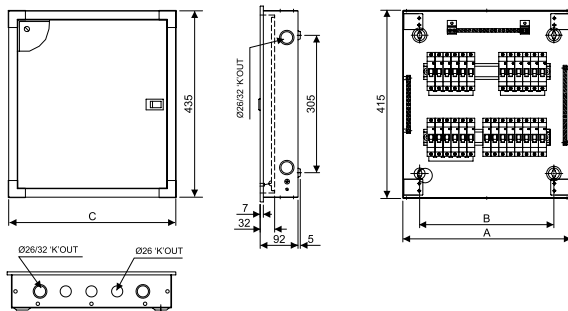

| Way | I/C | A | B | C | Top/Bottom | Top/Bottom | Side 'K'OUT |
|-----|-----|-----|-----|-----|------------|------------|-------------|
| | | | | | Ø26 | Ø26/32 | Ø26/32 |
| 4 | 8P | 330 | 255 | 350 | 6 Nos. | 4 Nos. | 4 Nos. |
| 6 | 8P | 370 | 295 | 390 | 6 Nos. | 4 Nos. | 4 Nos. |
| 8 | 8P | 440 | 365 | 460 | 8 Nos. | 4 Nos. | 4 Nos. |
| 12 | 8P | 630 | 555 | 650 | 16 Nos. | 4 Nos. | 4 Nos. |

IP43 Double Door – Glazed Door

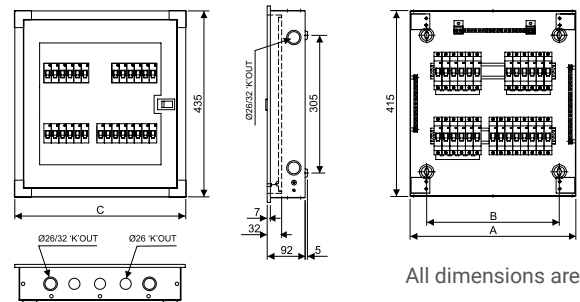

All dimensions are in mm

| Way | I/C | A | B | C | Top/Bottom | Top/Bottom | Side 'K'OUT |
|-----|-----|-----|-----|-----|------------|------------|-------------|
| | | | | | Ø26 | Ø26/32 | Ø26/32 |
| 4 | 8P | 330 | 255 | 350 | 6 Nos. | 4 Nos. | 4 Nos. |
| 6 | 8P | 370 | 295 | 390 | 6 Nos. | 4 Nos. | 4 Nos. |
| 8 | 8P | 440 | 365 | 460 | 8 Nos. | 4 Nos. | 4 Nos. |
| 12 | 8P | 630 | 555 | 650 | 16 Nos. | 4 Nos. | 4 Nos. |

Horizontal PPI DBs

Metal DBs for Three-Phase and Neutral (TPN) supply distribution with Per Phase Isolation (PPI)

- › As per IS 8623
- › Available in 4, 6, 8 & 12-way
- › Provision for FP MCB / Isolator / RCCB / RCBO as incomer, DP RCCB as sub incomer and SP MCBs as outgoing
- › Ready-to-use DB complete with colour-coded wire set, 100A insulated busbar, neutral bar/s with shroud/s, earth bar/s, cement-spill protector, cable ties, blanking plates and circuit identification label



Ordering Info.

| Description | Modules | | | IP43 Double Door |
|-------------|---------|-------------|----------|------------------|
| | Incomer | Sub-Incomer | Outgoing | |
| 4-way | 8 | 2+2+2 | 4+4+4 | PHP304DDB |
| 6-way | 8 | 2+2+2 | 6+6+6 | PHP306DDB |
| 8-way | 8 | 2+2+2 | 8+8+8 | PHP308DDB |
| 12-way | 8 | 2+2+2 | 12+12+12 | PHP312DDB |

Dimensions

IP43 Double Door – Metal Door

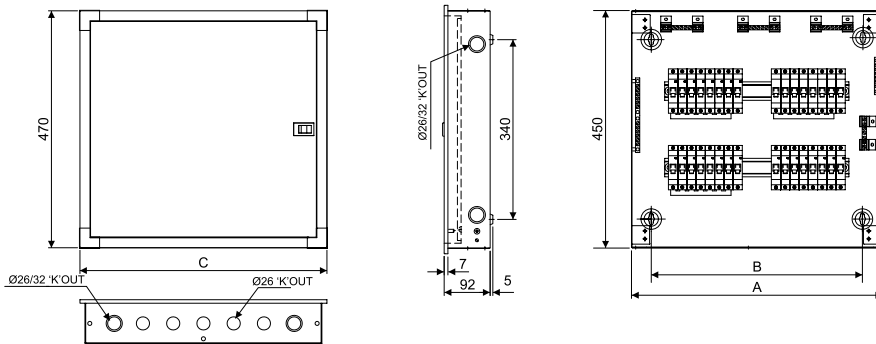

All dimensions are in mm

| Way | I/C | A | B | C | Top/Bottom | Top/Bottom | Side 'K'OUT |
|------|-----|-----|-----|-----|------------|------------|-------------|
| | | | | | Ø26 | Ø26/32 | Ø26/32 |
| 4+2 | 8P | 375 | 300 | 395 | 6 Nos. | 4 Nos. | 4 Nos. |
| 6+2 | 8P | 470 | 395 | 490 | 10 Nos. | 4 Nos. | 4 Nos. |
| 8+2 | 8P | 540 | 465 | 560 | 12 Nos. | 4 Nos. | 4 Nos. |
| 12+2 | 8P | 680 | 605 | 700 | 16 Nos. | 4 Nos. | 4 Nos. |

Phase Segregated DBs

Metal DBs for Three-Phase and Neutral (TPN) supply distribution with total phase segregation

- › As per IS 8623
- › Available in 4, 6, 8 & 12-way
- › Provision for FP MCB / Isolator as incomer in modular incomer, DP RCCB / RCBO as sub-incomer and SP MCBs as outgoing
- › Ready-to-use DB complete with colour-coded wire set, 100A insulated busbar, neutral bar/s with shroud/s, earth bar/s, cement-spill protector, cable ties, blanking plates and circuit identification label



Ordering Info.

| Description | Modules | | | IP43 Double Door |
|-------------|---------|-------------|----------|------------------|
| | Incomer | Sub-Incomer | Outgoing | |
| 4-way | 8 | 4+4+4 | 4+4+4 | PHS304DDB |
| 6-way | 8 | 4+4+4 | 6+6+6 | PHS306DDB |
| 8-way | 8 | 4+4+4 | 8+8+8 | PHS308DDB |
| 12-way | 8 | 4+4+4 | 12+12+12 | PHS312DDB |

Dimensions

IP43 Double Door – Metal Door (Modular I/C)

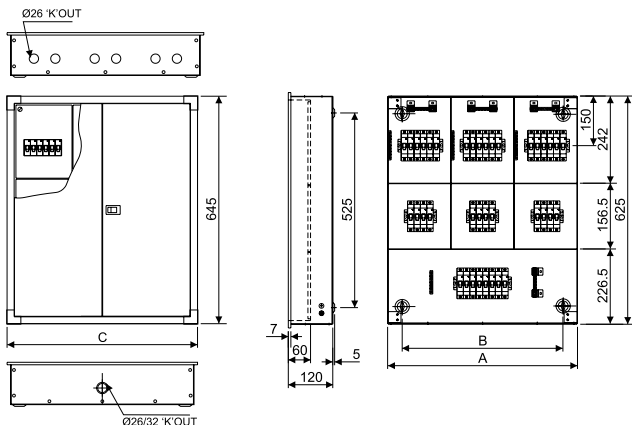

All dimensions are in mm

| Way | I/C | A | B | C | Ø26, 'K' OUT | Ø26/32 |
|-----|-----|-----|-----|-----|--------------|--------|
| | | | | | Top | Bottom |
| 4 | 8P | 410 | 330 | 430 | 6 Nos. | 1 No. |
| 6 | 8P | 520 | 440 | 540 | 6 Nos. | 1 No. |
| 8 | 8P | 630 | 550 | 650 | 9 Nos. | 1 No. |
| 12 | 8P | 845 | 765 | 865 | 12 Nos. | 1 No. |

Phase Selector DBs

Metal DBs for Three-Phase and Neutral (TPN) supply distribution with selector switches for phase selection

- › As per IS 8623
- › Available in 4, 6, 8 & 12-way
- › Provision for FP MCB / Isolator / RCCB / RCBO as incomer and SP MCBs as outgoing
- › Ready-to-use DB – provided with 63A Salzer rotary switches / colour-coded wire set, 100A insulated busbar, neutral bar/s with shroud/s, earth bar/s, cement-spill protector, cable ties, blanking plates and circuit identification label



Ordering Info.

| Description | Modules | | IP43 Double Door |
|-------------|---------|----------|------------------|
| | Incomer | Outgoing | |
| 4-way | 8 | 4+4+4 | PHC04DDB |
| 6-way | 8 | 6+6+6 | PHC06DDB |
| 8-way | 8 | 8+8+8 | PHC08DDB |
| 12-way | 8 | 12+12+12 | PHC12DDB |

Dimensions

IP43 Double Door – Metal Door

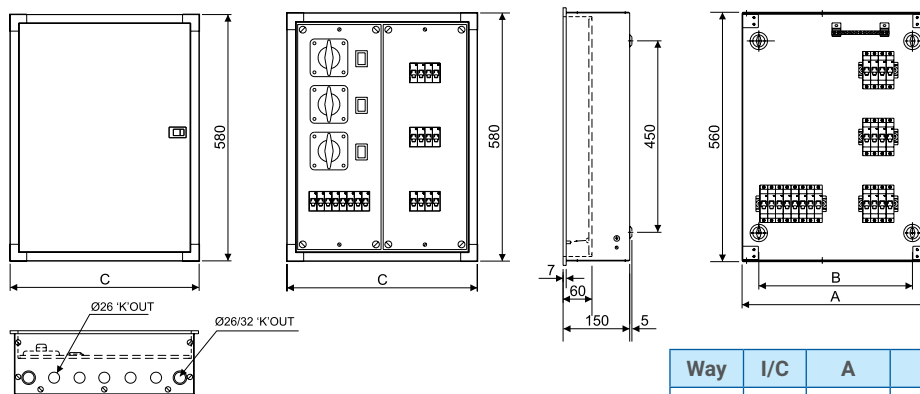

All dimensions are in mm

| Way | I/C | A | B | C | Top/Bottom | |
|-----|-----|-----|-----|-----|------------|---------------|
| | | | | | Ø26 'K'OUT | Ø26/32 'K'OUT |
| 4 | 8P | 420 | 350 | 440 | 8 Nos. | 4 Nos. |
| 6 | 8P | 455 | 385 | 475 | 10 Nos. | 4 Nos. |
| 8 | 8P | 490 | 420 | 510 | 10 Nos. | 4 Nos. |
| 12 | 8P | 560 | 490 | 580 | 14 Nos. | 4 Nos. |

VTPN DBs with Modular Incomer

Metal DBs with vertical busbar for Three-Phase and Neutral (TPN) supply distribution

- › As per IS 8623
- › Available in 4, 6, 8 & 12-way
- › Provision for FP MCB / Isolator / RCCB / RCBO as incomer and SP / TP MCBs as outgoing
- › Ready-to-use DB complete with colour-coded wire set, neutral bar/s, earth bar/s, cement-spill protector, cable ties, blanking plates and circuit identification label



| Description | Modules | | IP43 Double Door |
|-------------|---------|----------|------------------|
| | Incomer | Outgoing | |
| 4-way | 8 | 4+4+4 | PHV304DDB |
| 6-way | 8 | 6+6+6 | PHV306DDB |
| 8-way | 8 | 8+8+8 | PHV308DDB |
| 12-way | 8 | 12+12+12 | PHV312DDB |

Dimensions

IP43 Double Door – Metal Door

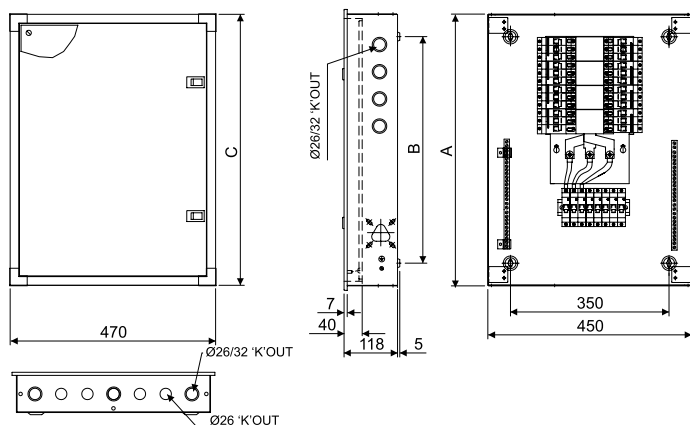

All dimensions are in mm

| Way | I/C | A | B | C | Top/Bottom | Top/Bottom | Side 'K'OUT |
|-----|-----|-----|-----|-----|------------|------------|-------------|
| | | | | | Ø26 | Ø26/32 | Ø26/32 |
| 4 | 8P | 500 | 400 | 520 | 8 Nos. | 6 Nos. | 4 Nos. |
| 6 | 8P | 550 | 450 | 570 | 8 Nos. | 6 Nos. | 6 Nos. |
| 8 | 8P | 600 | 500 | 620 | 8 Nos. | 6 Nos. | 8 Nos. |
| 12 | 8P | 700 | 600 | 720 | 8 Nos. | 6 Nos. | 12 Nos. |

VTPN DBs with MCCB Incomer

Metal DBs with vertical busbar for Three-Phase and Neutral (TPN) supply distribution with MCCB as incomer

- › As per IS 8623
- › Available in 4, 6, 8 & 12-way
- › Provision for MCCB as incomer and SP / TP MCBs as outgoing
- › Suitable for 3-Pole & 4-Pole MCCB as incomer. Up to 125A – DY125U
- › Ready-to-use DB complete with colour-coded wire set, neutral bar/s with shroud/s, earth bar/s, cement-spill protector, cable ties, blanking plates and circuit identification label



Ordering Info.

| Description | Modules | | IP43 Double Door |
|-------------|---------|----------|------------------|
| | Incomer | Outgoing | |
| 4-way | 8 | 4+4+4 | PHV304DDM |
| 6-way | 8 | 6+6+6 | PHV306DDM |
| 8-way | 8 | 8+8+8 | PHV308DDM |
| 12-way | 8 | 12+12+12 | PHV312DDM |

Dimensions

IP43 Double Door – Metal Door

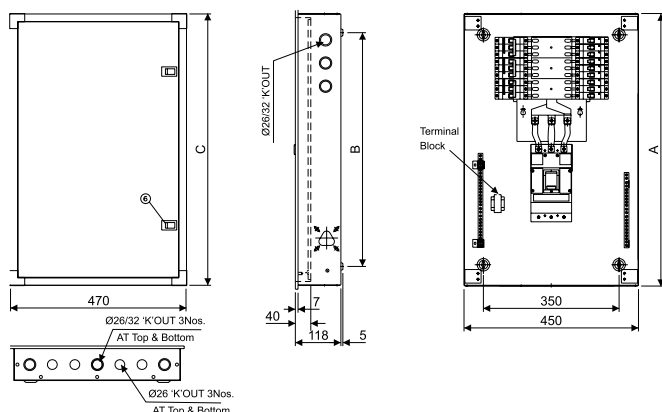

All dimensions are in mm

| Way | I/C | A | B | C | Top/Bottom | Top/Bottom | Side 'K'OUT |
|-----|------|-----|-----|-----|------------|------------|-------------|
| | | | | | Ø26 | Ø26/32 | Ø26/32 |
| 4 | MCCB | 653 | 550 | 673 | 8 Nos. | 6 Nos. | 4 Nos. |
| 6 | MCCB | 700 | 600 | 720 | 8 Nos. | 6 Nos. | 6 Nos. |
| 8 | MCCB | 757 | 657 | 777 | 8 Nos. | 6 Nos. | 8 Nos. |
| 12 | MCCB | 864 | 764 | 884 | 8 Nos. | 6 Nos. | 12 Nos. |

Enclosures

Metal enclosures for flush and surface mounting

- › As per IS 8623
- › Available in 2, 3, 4 & 6-way
- › Provision to mount MCB / Isolator / RCCB / RCBO and other modular devices.



Ordering Info.

| Description | Modules | IP30 Single Door |
|-------------|---------|------------------|
| 2-way | 2 | PHE02DB |
| 3-way | 3 | PHE03DB |
| 4-way | 4 | PHE04DB |
| 6-way | 6 | PHE06DB |

Dimensions

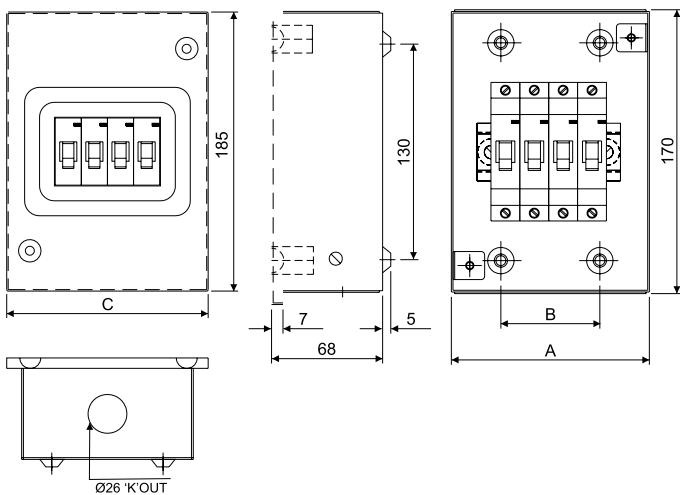

All dimensions are in mm

| Way | A | B | C | Dia 23 'K'OUT | |
|-----|-----|----|-----|---------------|--------|
| | | | | Top | Bottom |
| 2 | 85 | 40 | 100 | 1 No. | 1 No. |
| 3 | 120 | 60 | 135 | 1 No. | 1 No. |
| 4 | 120 | 60 | 135 | 1 No. | 1 No. |
| 6 | 155 | 95 | 170 | 2 Nos. | 2 Nos. |

Plug & Socket DBs

Metal-clad plug & socket outlets for supplying loads

- › As per IS 8623
- › SPN - 10A & 20A; TPN - 32A
- › Provision to mount MCBs / RCCBs
- › Ready-to-use DBs, complete with colour-coded wire set, neutral bar/s with shroud/s in 1 and 3 modules



Ordering Info.

| Description | Modules | IP43 Double Door |
|---------------|---------|------------------|
| 10A, 2 Pin+SC | 1 | PMP110DB |
| 20A, 2 Pin+SC | 1 | PMP120DB |
| 20A, 2 Pin+SC | 2 | PMP220DB |
| 32A, 3 Pin+SC | 3 | PMP332DB |

Dimensions

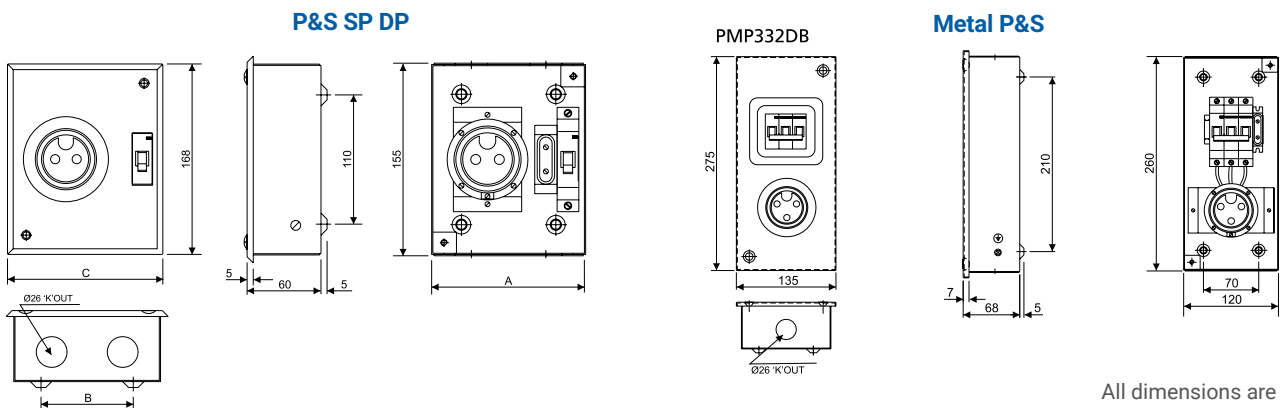

All dimensions are in mm

| Modules | A | B | C | Dia 23 'K'OUT | |
|---------|-----|----|-----|---------------|--------|
| | | | | Top | Bottom |
| 1 | 124 | 78 | 137 | 2 Nos. | 2 Nos. |
| 1 | 124 | 78 | 137 | 2 Nos. | 2 Nos. |
| 2 | 124 | 78 | 137 | 2 Nos. | 2 Nos. |

Tripbox

- › As per IS 8623
- › Suitable for surface and flush mounting
- › Material: CRCA sheet steel, RAL 9010 - glossy finish
- › Ready-to-use DB complete with colour-coded wire set, 100A CU busbar, neutral bar, earth bar and DIN channel



Ordering Info.

| SPN | Description | Modules | IP30 Single Door | IP43 Double Door |
|-----|-------------|---------|------------------|------------------|
| | 4-way | 4 | BH104SDB | BH104DDB |
| | 6-way | 6 | BH106SDB | BH106DDB |
| | 8-way | 8 | BH108SDB | BH108DDB |
| | 12-way | 12 | BH112SDB | BH112DDB |
| | 16-way | 16 | BH116SDB | BH116DDB |

| TPN | Description | Modules | | IP30 Single Door | IP43 Double Door |
|--------|-------------|----------|----------|------------------|------------------|
| | | Incomer | Outgoing | | |
| | 4-way | 8 | 4+4+4 | BH304SDB | BH304DDB |
| | 6-way | 8 | 6+6+6 | BH306SDB | BH306DDB |
| | 8-way | 8 | 8+8+8 | BH308SDB | BH308DDB |
| 12-way | 8 | 12+12+12 | BH312SDB | BH308DDB | |

| Phase Selector* | Description | Modules | | IP43 Double Door |
|-----------------|-------------|---------|----------|------------------|
| | | Incomer | Outgoing | |
| | 4-way | 8 | 4+4+4 | BHC04DDB |
| 6-way | 8 | 6+6+6 | BHC06DDB | |

*With 40A selector switches.

Dimensions

All dimensions are in mm

SPN Single-Door

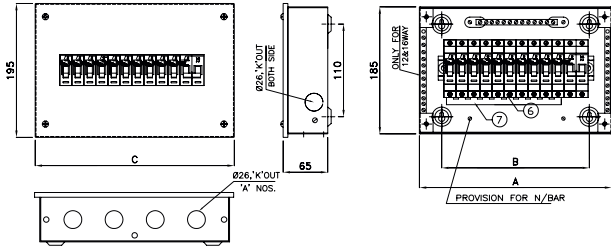

| Cat No. | A | B | C | 26 'K'OUT 'A'nos. | |
|----------|-----|-----|-----|-------------------|--------|
| | | | | Top | Bottom |
| BH104SDB | 137 | 74 | 147 | 2 Nos. | 2 Nos. |
| BH106SDB | 173 | 110 | 183 | 2 Nos. | 2 Nos. |
| BH108SDB | 209 | 132 | 219 | 3 Nos. | 3 Nos. |
| BH112SDB | 280 | 203 | 290 | 4 Nos. | 4 Nos. |
| BH116SDB | 355 | 278 | 365 | 5 Nos. | 5 Nos. |

SPN Double-Door

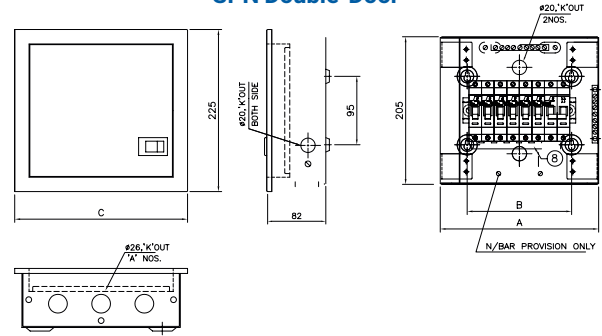

| Cat No. | A | B | C | 26 'K'OUT 'A'nos. | |
|----------|-----|-----|-----|-------------------|--------|
| | | | | Top | Bottom |
| BH104DDB | 145 | 70 | 165 | 2 Nos. | 2 Nos. |
| BH106DDB | 180 | 105 | 200 | 2 Nos. | 2 Nos. |
| BH108DDB | 220 | 145 | 240 | 3 Nos. | 3 Nos. |
| BH112DDB | 295 | 220 | 315 | 4 Nos. | 4 Nos. |
| BH116DDB | 365 | 290 | 385 | 5 Nos. | 5 Nos. |
| BH118DDB | 410 | 335 | 430 | 6 Nos. | 6 Nos. |

TPN Single-Door

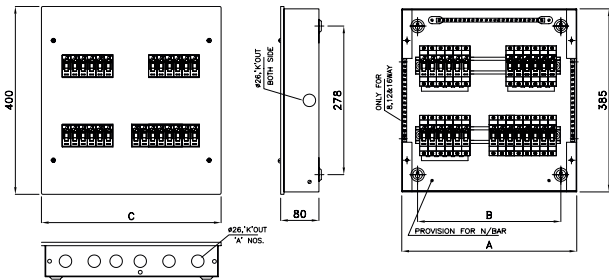

| Cat No. | A | B | C | 26 'K'OUT 'A'nos. | |
|----------|-----|-----|-----|-------------------|--------|
| | | | | Top | Bottom |
| BH304SDB | 305 | 220 | 320 | 4 Nos. | 4 Nos. |
| BH306SDB | 360 | 275 | 385 | 5 Nos. | 5 Nos. |
| BH308SDB | 397 | 311 | 412 | 6 Nos. | 6 Nos. |
| BH312SDB | 550 | 464 | 565 | 8 Nos. | 8 Nos. |

TPN Double-Door

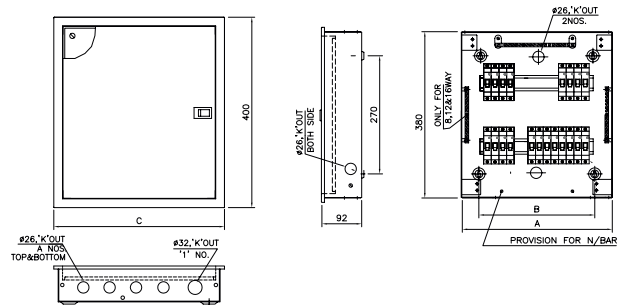

| Cat No. | A | B | C | 26 'K'OUT 'A'nos. | |
|----------|-----|-----|-----|-------------------|----------|
| | | | | Top & Bottom | BX. Door |
| BH304SDB | 305 | 220 | 320 | 4 Nos. | S. Door |
| BH306SDB | 360 | 275 | 385 | 4 Nos. | S. Door |
| BH308SDB | 397 | 311 | 412 | 5 Nos. | S. Door |
| BH312SDB | 550 | 464 | 565 | 8 Nos. | D. Door |

Phase Selector

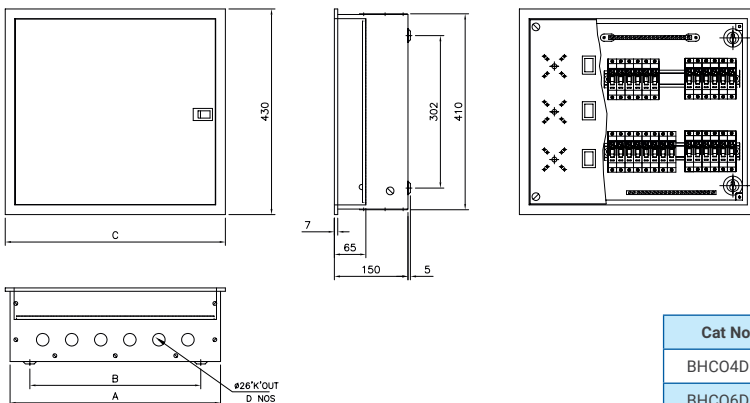

| Cat No. | Way | I/C | A | B | C | 26 'K'OUT 'A'nos. | |
|----------|-----|-----|-----|-----|-----|-------------------|--------|
| | | | | | | Top | Bottom |
| BHCO4DDB | 4 | 12 | 430 | 360 | 450 | 6 Nos. | 6 Nos. |
| BHCO6DDB | 6 | 18 | 465 | 395 | 485 | 7 Nos. | 7 Nos. |

Protect yourself against electric shock

'Short-circuit' is the term commonly used to describe various electrical faults. A short-circuit is caused by 2 or 3 phases getting shorted or shorting between phase to neutral. During this phenomenon, the system experiences an abnormally high flow of current which can damage the equipment / installations and even cause a fire. Electrical devices like HRC fuses, circuit breakers (MCBs, MCCBs, etc.) are commonly used for protection against such short-circuit faults.

Circuit Breakers like MCBs, MCCBs and HRC fuses do not detect 'leakage currents' which are dangerous to humans and livestock. Leakage current can also lead to a fire. Therefore we need a protection device which detects such leakage currents and disconnects the circuit if they occur.

An RCCB – Residual Current Circuit Breaker – is the device which does precisely this function. It is also called an Earth Leakage Circuit Breaker (ELCB).

Effects of Leakage Current on the Human Body

The effects of various current levels on the human body are shown here:

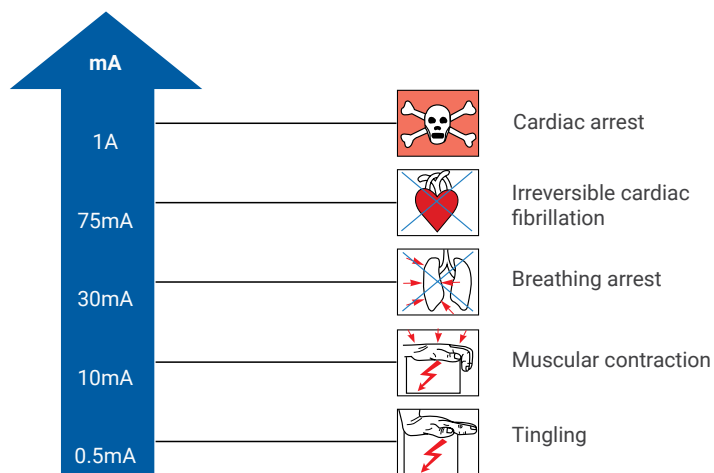

> The gravity of an electric shock depends on:

- » Current value
- » Time for which current remains in the human body
- » Path that current takes through the human body
- » Resistance of the human body

- > When a current in excess of 30mA flows through the human body, the person runs the risk of being harmed if this current is not interrupted in a relatively short time.

Working Principal of an RCCB

An RCCB or Residual Current Device (RCD) offers leakage protection by constantly monitoring the current flowing in the live and neutral wires supplying a circuit or individual equipment. Under normal circumstances, the current flowing in the two wires is equal.

> Earth leakage current will flow in the circuit due to:

- » Poor insulation of wire/equipment, and
- » Accidental human contact with live/faulty equipment/circuit.

A correctly selected RCCB will detect current leakage due to these conditions – and trip.

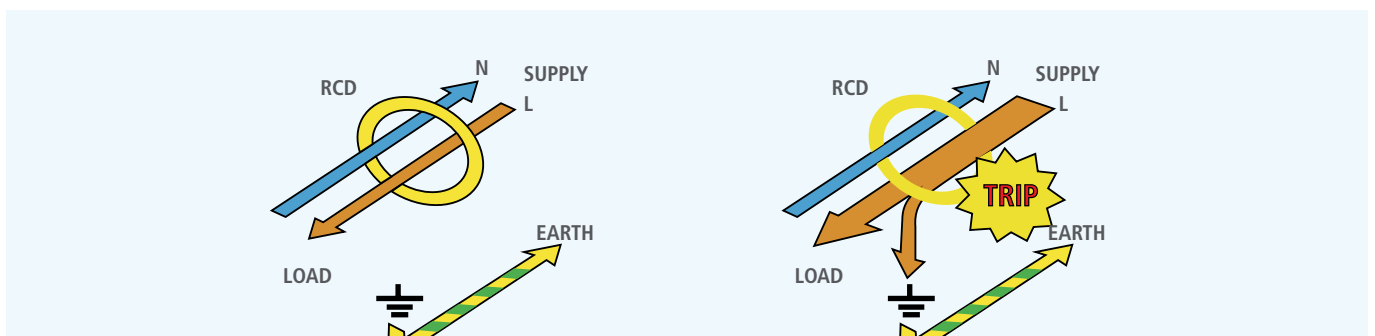

EL+MCB is also part of the RCD family offering 3-in-1 protection against short-circuit, overload and earth leakage.

Different sensitivities in RCCBs

Sensitivity in mA is one of the technical parameters of an RCCB. It indicates the tripping threshold of the product. Accordingly, RCCB with 30mA sensitivity will not trip below 50% of rated sensitivity value (15mA in this case) and will definitely trip

beyond 15mA and up to 30mA. RCCBs are typically offered in 30mA, 100mA and 300mA sensitivities. Typical applications of RCCBs with these sensitivities can be as below:



| Sensitivity | Typical Application |
|-------------|---|
| 30mA | Human Protection – Kitchens, bathrooms, laboratories, schools and workshops, etc. |
| 100mA | Protection against indirect contact, limited personal protection |
| 300mA | Cable/fire protection in an industrial environment |

Precautions for installing an RCCB

- › Wiring should be done as per the wiring diagram, by a trained and qualified electrician.
- › All wiring necessary for operation shall be passed through the RCCB.
- › All equipment must be properly earthed.
- › To ensure correct functioning, care must be taken that the neutral conductor on the load side of the RCCB must not be connected to earth, otherwise nuisance tripping may occur or tripping may be impaired.
- › In case individual RCCBs are used as sub-incomers in R, Y and B phases, outgoing neutrals of these RCCBs should not be looped together, separating all three phases/circuits electrically.
- › An overcurrent protection device such as an MCB or HRC fuse shall be used for protection of the circuit under installation.

Test Button Facility in RCCBs

As RCCBs provide protection against leakage current, one needs to be certain that these products are always ready to act whenever current leaks. To obtain this assurance, there is the provision of a 'Test Button' in RCCBs. While the RCCB is

energized (given necessary power supply), one can press the test button, which will activate the mechanism inside and make the RCCB trip. It shows that the RCCB is in good condition and is ready to provide leakage current protection.



Why an RCCB should not be bypassed

If the sensitivity selection of an RCCB is not done properly, it might trip when not required. And one of the reasons for bypassing RCCBs is unwanted tripping.

For example, the circuit demands that an 100mA RCCB be installed; the RCCB will not trip up to 50mA and will trip in the band beyond 50mA and up to 100mA. Now, on account of

incorrect selection, if a 30mA RCCB is installed in this circuit, it might trip needlessly.

If the RCCB is bypassed, there will not be any leakage protection device in the system, leading to electric shock and a fire. Therefore, it is important to select an RCCB with right sensitivity and not bypass it in the system.

Switchgear Training Centres



Pune

Lauritz Knudsen Electrical & Automation
Switchgear Training Centre
T-156 / 157, MIDC,
Bhosari, Pune - 411 026
Tel: 020-2712 0037 / 2712 0653
E-mail: STC-PUNE@LK-EA.com



Lucknow

Lauritz Knudsen Electrical & Automation
Switchgear Training Centre
C-6 & 7, UPSIDC,
P. O. Sarojininagar,
Lucknow - 226 008
Tel: 97944 54455
E-mail: STC-LUCKNOW@LK-EA.com



Delhi

Lauritz Knudsen Electrical & Automation
Switchgear Training Centre
A-25, Imperia Complex, First Floor
Mohan Cooperative Industrial Estate
Near Sarita Vihar / Mohan Estate Metro Station
Main Mathura Road, New Delhi - 110044
Tel: 9899020306 / 9720186726 / 9560845094
E-mail: STC-DELHI@LK-EA.com



Kolkata

Lauritz Knudsen Electrical & Automation
Switchgear Training Centre,
2nd Floor, Block BN3, Sector V,
Salt Lake City,
Kolkata - 700091, West Bengal
Tel: 7738717893 / 7797795567
E-mail: STC-KOLKATA@LK-EA.com



Vadodara

Lauritz Knudsen Electrical & Automation
Switchgear Training Centre
Behind L&T Knowledge City,
Near Village Ankhol,
Vadodara - 390019
Tel: 0265 6147805 / 6147808
E-mail: STC-VADODARA@LK-EA.com



Coonor

Lauritz Knudsen Electrical & Automation
Switchgear Training Centre
Ooty-Coonor Main Road
Yellanahalli P.O.,
The Nilgiris - 643 243
Tel: 0423 251 7107
E-mail: STC-COONOOR@LK-EA.com

Customer Interaction Center (CIC)
Phone no: 022 6932 7800
Web: www.LK-EA.com | e-mail: CIC@LK-EA.com



Electrical Standard Products (ESP) Offices

HEAD OFFICE

Lauritz Knudsen Electrical & Automation, A/600, Shil-Mahape Road, TTC Industrial Area, MIDC Thane, Navi Mumbai, 400 710, Maharashtra.

Tel: 022-6722 6300 | Fax: 022-6705 1112 | e-mail: CIC@LK-EA.com

BRANCH OFFICES

Lauritz Knudsen Electrical & Automation
C-201, The First Commercial Complex,
B/S Keshavbaug Party Plot, Vastrapur,
Ahmedabad - 380 015
Phone No: 022-6932 7800
e-mail: CIC@LK-EA.com

Lauritz Knudsen Electrical & Automation
Shri Daneshwari, 1st Floor,
Plot No. 17, 2nd Cross, Near Old Income
Tax Office Road, Vidyanagar,
Hubballi - 580 021
Phone No: 022-6932 7800
e-mail: CIC@LK-EA.com

Lauritz Knudsen Electrical & Automation
No.10, Fortuna Towers, 2nd Floor,
Rana Pratap Marg, Near NBRI,
Lucknow - 226 001
Phone No: 022-6932 7800
e-mail: CIC@LK-EA.com

Lauritz Knudsen Electrical & Automation
A06/A07, Second Floor,
Grand Chandra Complex, Frazer Road
Patna - 800 001
Phone No: 022-6932 7800
e-mail: CIC@LK-EA.com

Lauritz Knudsen Electrical & Automation
Wework Central, #36 Infantry Road,
Bengaluru - 560 001
Phone No: 022-6932 7800
e-mail: CIC@LK-EA.com

Lauritz Knudsen Electrical & Automation
AWFIS Space Solutions, Prestige Phoenix,
4th floor, 1405, Umanagar, Begumpet,
Hyderabad - 500 016
Phone No: 022-6932 7800
e-mail: CIC@LK-EA.com

Lauritz Knudsen Electrical & Automation
El Dorado Building, 3rd Floor, 6,
Venkatraman Street, Chinna Chokkikulam,
Madurai - 625 002
Phone No: 022-6932 7800
e-mail: CIC@LK-EA.com

Lauritz Knudsen Electrical & Automation
UrbanWrk, 5th Floor, Sai Radhe,
Raja Bahadur Mill Road, Behind Hotel
Grand Sheraton, Sangamwadi
Pune - 411 001
Phone No: 022-6932 7800
e-mail: CIC@LK-EA.com

Lauritz Knudsen Electrical & Automation
Workloop Unit-612, 6th Floor,
Esplanade One, Rasulgarh,
Bhubaneswar, Odisha-751010
Phone No: 022 6932 7800
e-mail: CIC@LK-EA.com

Lauritz Knudsen Electrical & Automation
Workie, 214 - 2nd Floor,
Apollo Premier, PU-4,
Scheme No. 54, Vijay Nagar Square,
Indore - 452 010
Phone No: 022-6932 7800
e-mail: CIC@LK-EA.com

Lauritz Knudsen Electrical & Automation
Bestech Business Park,
Tower - A, 2nd floor, Sector - 66
Mohali - 160059
Phone No: 022-6932 7800
e-mail: CIC@LK-EA.com

Lauritz Knudsen Electrical & Automation
Office No. 211 & 212, Pithalia Plaza,
KK Road, Near Fafadih Chowk,
Raipur - 492 001
Phone No: 022-6932 7800
e-mail: CIC@LK-EA.com

Lauritz Knudsen Electrical & Automation,
The Executive Centre
Level 8, Olympia Teknos Park
28, SIDCO Industrial Estate, Guindy,
Chennai - 600 032, Tamil Nadu,
Phone No: 022-6932 7800
e-mail: CIC@LK-EA.com

Lauritz Knudsen Electrical & Automation
Office No. 430, 4th Floor,
Jaipur Electronic Market, Riddhi Siddhi,
Gopalpura Bypass,
Jaipur - 302 018
Phone No: 022-6932 7800
e-mail: CIC@LK-EA.com

Lauritz Knudsen Electrical & Automation
TC II, Tower B, PRIMA BAY Gate No. 5,
Saki Vihar Road Powai,
Mumbai - 400 072
Phone No: 022-6932 7800
e-mail: CIC@LK-EA.com

Lauritz Knudsen Electrical & Automation,
DevX 4th Floor, A Wing, Om 9 Square,
150 Ft Ring Road, Near Nana Mava Circle,
Opp Silver Heights,
Rajkot - 360 001
Phone No: 022-6932 7800
e-mail: CIC@LK-EA.com

Lauritz Knudsen Electrical & Automation
Playworkz Coworking Space
43 & 44, 3rd Cross,
Bharathy Colony, Peelamedu,
Coimbatore - 641 004
Phone No: 022-6932 7800
e-mail: CIC@LK-EA.com

Lauritz Knudsen Electrical & Automation
GDR Siddha, Ground Floor, N Road
Bistupur, Opposite St. Mary's Church,
Jamshedpur - 831 001
Phone No: 022-6932 7800
e-mail: CIC@LK-EA.com

Lauritz Knudsen Electrical & Automation
Unnati Building, 2nd Floor,
Automation Campus, A-600, TTC Industrial
Area Shil-Mahape Road, Mahape,
Navi Mumbai - 400 710
Phone No: 022-6932 7800
e-mail: CIC@LK-EA.com

Lauritz Knudsen Electrical & Automation
10th Floor, Titaanium Business,
Bhimrad Road, Althan
Surat - 395 017
Phone No: 022-6932 7800
e-mail: CIC@LK-EA.com

Lauritz Knudsen Electrical & Automation
3rd Floor, 1&2 Vijay Park,
Main Chakrata Road, Opp. Anandam,
Near Ballapur chowk,
Dehradun - 248 001
Phone No: 022-6932 7800
e-mail: CIC@LK-EA.com

Lauritz Knudsen Electrical & Automation
Business Communication Centre
2nd Floor, Chiramel Chambers,
Kurisupally Road, Ravipuram,
Kochi - 682 015
Phone No: 022-6932 7800
e-mail: CIC@LK-EA.com

Lauritz Knudsen Electrical & Automation
M1 & M2, Mezzanine Floor,
Himalaya Excellency,
Plot No. C-47, Pratap Nagar Square,
Nagpur - 440 022
Phone No: 022-6932 7800
e-mail: CIC@LK-EA.com

Lauritz Knudsen Electrical & Automation
11th Floor, Block-D, Notus IT Park,
Sarabhai Campus, Bhailal Amin Marg,
Vadodara - 390 023
Phone No: 022-6932 7800
e-mail: CIC@LK-EA.com

Lauritz Knudsen Electrical & Automation
Ground Floor, B-27,
Biplab Rashbihari Sarani,
Sector 2A, Bidhan Nagar,
Durgapur - 713 212
Phone No: 022-6932 7800
e-mail: CIC@LK-EA.com

Lauritz & Knudsen Electrical & Automation,
207, 2nd floor, Revolution Complex,
Station Road, E Ward,
Next to Pedestrian Bridge,
Kolhapur - 416 001
Phone No: 022-6932 7800
e-mail: CIC@LK-EA.com

Lauritz Knudsen Electrical & Automation,
3rd floor, Uttam Tower by Viraj Estate,
Sharanpur Road,
Nasik - 422 002
Phone No: 022-6932 7800
e-mail: CIC@LK-EA.com

Lauritz Knudsen Electrical & Automation
Naga Chambers, 3rd Floor, D/No. 12-1-16,
Plot No. 49, Survey No. 1051, Waltair Main Road,
Visakhapatnam - 530 002
Phone No: 022-6932 7800
e-mail: CIC@LK-EA.com

Lauritz Knudsen Electrical & Automation
6th Floor, Exotica Greens, A Block, 191,
R G Baruah Road, Guwahati Central,
Guwahati - 781 005
Phone No: 022-6932 7800
e-mail: CIC@LK-EA.com

Lauritz Knudsen Electrical & Automation
2nd Floor, BN3, Salt Lake, Sector-V,
Kolkata - 700 091
Phone No: 022-6932 7800
e-mail: CIC@LK-EA.com

Lauritz Knudsen Electrical & Automation
A-25, 1st Floor, Imperia Complex,
Mohana Corporate Industrial Estate,
Near Sarita Vihar Metro Station,
Mathura Road,
New Delhi - 110 044
Phone no: 022-6932 7800
e-mail: CIC@LK-EA.com

Product improvement is a continuous process. For the latest information and special application, please contact any of our offices listed here. Product photographs shown for representative purpose only.



Lauritz Knudsen Electrical & Automation, Electrical Standard Product

A/600, Shil-Mahape Road, TTC Industrial Area, MIDC Thane, Navi Mumbai, 400 710, Maharashtra, Phone No: 022-6722 6300 | Web: www.LK-EA.com

Customer Interaction Center (CIC)

Phone no: 022-6932 7800

Web: www.LK-EA.com | e-mail: CIC@LK-EA.com